



PL-2303HX Edition USB to Serial Bridge Controller Product Datasheet

Document Revision: 1.5D

Document Release: April 26, 2005

Prolific Technology Inc.

7F, No. 48, Sec. 3, Nan Kang Rd.

Nan Kang, Taipei 115, Taiwan, R.O.C.

Telephone: +886-2-2654-6363

Fax: +886-2-2654-6161

E-mail: sales@prolific.com.tw

Website: <http://www.prolific.com.tw>



Disclaimer

All the information in this document is subject to change without prior notice. Prolific Technology Inc. does not make any representations or any warranties (implied or otherwise) regarding the accuracy and completeness of this document and shall in no event be liable for any loss of profit or any other commercial damage, including but not limited to special, incidental, consequential, or other damages.

Trademarks

The Prolific logo is a registered trademark of Prolific Technology Inc. All brand names and product names used in this document are trademarks or registered trademarks of their respective holders.

Copyrights

Copyright © 2005 Prolific Technology Inc. All rights reserved.

No part of this document may be reproduced or transmitted in any form by any means without the express written permission of Prolific Technology Inc.

Revision History

Revision	Description	Date
1.5D	➤ Modify Operating Temperature Characteristics (Sec 8.4)	April 26, 2005
1.5C	<ul style="list-style-type: none"> ➤ Modify Features section ➤ Modify List of Tables ➤ Modify notes for Pin Assignment section ➤ Modify DC and Temperature Characteristics section 	March 11, 2005
1.5B	➤ Add Lead-Free Ordering Information	March 8, 2005
1.5	<ul style="list-style-type: none"> ➤ Added List of Figures and List of Tables ➤ Modify Features section (Sec 1.0) ➤ Improve clarity of Functional Block diagram (Sec 2.0) and Pin Assignment diagram (Sec 4.0) ➤ Change Minimum Operating Temperature to 0°C. 	January 27, 2005
1.4B	<ul style="list-style-type: none"> ➤ Added IC quantity per reel information (Sec 10.1) ➤ Added Ordering Information (Sec 11.0) 	January 19, 2005
1.4	➤ Added Reel Packing Information	January 6, 2005
1.3	<ul style="list-style-type: none"> ➤ Modify Minimum Operating Voltage Range to 4.4V ➤ Correct some spelling errors 	October 21, 2004
1.2	<ul style="list-style-type: none"> ➤ Correct page 6 (3.0 Introduction) by removing 5V range: <i>"Flexible signal level requirement on the RS232-like serial port side also allows PL-2303HX to connect directly to any 3.3V~1.8V range devices."</i> 	April 23, 2004
1.1	<ul style="list-style-type: none"> ➤ Added notes on Pin Assignment and Description section regarding level and driving capabilities ➤ Modify DC Characteristics table 	February 18, 2004
1.0	➤ PL-2303HX Product Datasheet – Formal Release	February 2004

Table of Contents

1.0 FEATURES	6
2.0 FUNCTIONAL BLOCK DIAGRAM	7
3.0 INTRODUCTION.....	8
4.0 PIN ASSIGNMENT OUTLINE	9
5.0 PIN ASSIGNMENT & DESCRIPTION.....	10
6.0 USB STANDARD DESCRIPTORS	11
6.1 Device Descriptor	11
6.2 Configuration Descriptor	11
6.3 Interface Descriptor	12
6.4 Endpoint 1 Descriptor: Interrupt Input Endpoint.....	12
6.5 Endpoint 2 Descriptor: Bulk Data Output endpoint	12
6.6 Endpoint 3 Descriptor: Bulk Data Input endpoint	13
6.7 String Descriptors	13
7.0 USB STANDARD REQUESTS	14
8.0 DC & TEMPERATURE CHARACTERISTICS.....	15
8.1 Absolute Maximum Ratings	15
8.2 DC Characteristics.....	15
8.3 Clock Characteristics	17
8.4 Temperature Characteristics.....	17
8.5 Leakage Current and Capacitance	17
8.6 Power-On Reset	18
9.0 OUTLINE DIAGRAM.....	19
9.1 SSOP28 Package.....	19
10.0 REEL PACKING INFORMATION.....	20
10.1 Carrier Tape (SSOP-28)	20
10.2 Reel Dimension	21
11.0 ORDERING INFORMATION	21

List of Figures

Figure 2-1 Block Diagram of PL-2303HX.....	7
Figure 4-1 Pin Assignment Outline of PL-2303HX.....	9
Figure 8-1 Power-On Reset Diagram	18
Figure 9-1 Outline Diagram of PL-2303HX SSOP28	19
Figure 10-1a SSOP28 Carrier Tape.....	20
Figure 10-1b IC Reel Placements.....	20
Figure 10-2 Reel Dimension	21

List of Tables

Table 5-1 Pin Assignment & Description	10
Table 6-1 Device Descriptor.....	11
Table 6-2 Configuration Descriptor	11
Table 6-3 Interface Descriptor.....	12
Table 6-4 Endpoint1 Descriptor.....	12
Table 6-5 Endpoint2 Descriptor.....	12
Table 6-6 Endpoint3 Descriptor.....	13
Table 6-7-1 String Descriptor – Language ID.....	13
Table 6-7-2 String Descriptor – Manufacturer	13
Table 6-7-3 String Descriptor – Product.....	14
Table 6-7-4 String Descriptor – Serial Number	14
Table 8-1 Absolute Maximum Ratings.....	15
Table 8-2 Operating Voltage and Suspend Current	15
Table 8-2-1 3.3V I/O Pins.....	15
Table 8-2-2a VDD_325@3.3V Serial I/O Pins	16
Table 8-2-2b VDD_325@2.5V Serial I/O Pins	16
Table 8-2-2c VDD_325@1.8V Serial I/O Pins.....	16
Table 8-3 Clock Characteristics	17
Table 8-4 Temperature Characteristics	17
Table 8-5 Leakage Current and Capacitance.....	17
Table 8-6 Power-On Reset.....	18
Table 9-1 Package Dimension	19
Table 10-2 Reel Part Number Information	21
Table 11-1 Ordering Information.....	21

1.0 Features

- Fully Compliant with USB Specification v2.0 (Full-Speed)
- On Chip USB 1.1 transceiver, 5V→3.3V regulator, and 12 MHz crystal oscillator
- Supports RS232-like Serial Interface
 - Full-duplex transmitter and receiver (TXD and RXD)
 - Six MODEM control pins (RTS, CTS, DTR, DSR, DCD, and RI)
 - 5, 6, 7 or 8 data bits
 - Odd, Even, Mark, Space, or None parity mode
 - One, one and a half, or two stop bits
 - Parity error, frame error, and serial break detection
 - Programmable baud rate from 75 bps to 6 Mbps
 - External RS232 driver power down control
 - Independent power source for serial interface
- Extensive Flow Control Mechanism
 - Adjustable high/low watermark level
 - Automatic flow control with CTS/RTS
 - Automatic flow control with XON/XOFF
 - Inbound data buffer overflow detection
- Configurable 512-byte bi-directional data buffer
 - 256-byte outbound buffer and 256-byte inbound buffer; or
 - 128-byte outbound buffer and 384-byte inbound buffer
- Supports remote wake-up from MODEM input signals
- Two general purpose I/O (GPIO) pins
- Optional external EEPROM for startup device configurations
- Provides drivers support for Windows, Mac OS, Linux, and WinCE
- Designed for Windows XP Certified Logo Drivers
- USB-IF Logo Compliant with TID 40002448
- Small footprint 28-pin SSOP IC package

2.0 Functional Block Diagram

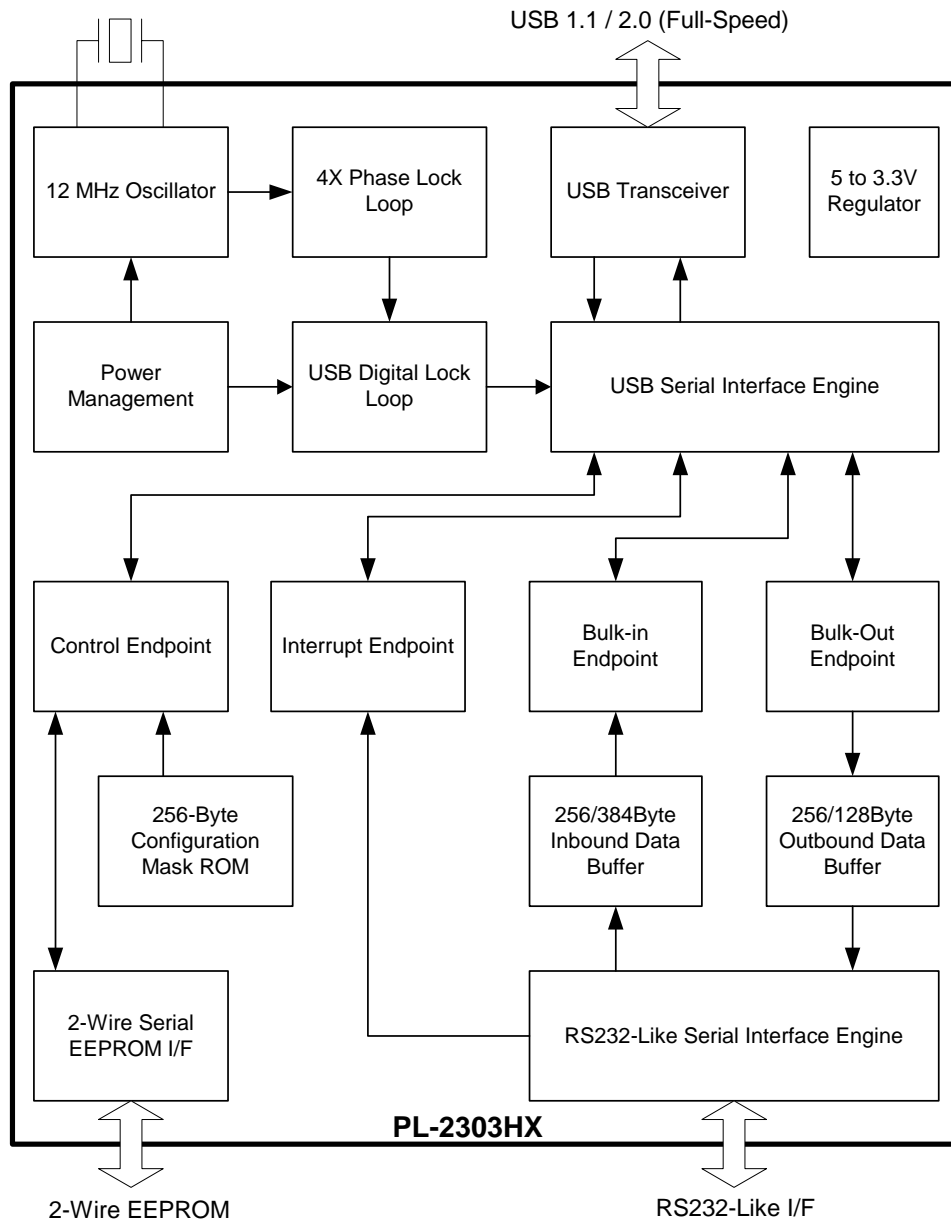

Figure 2-1 Block Diagram of PL-2303HX

3.0 Introduction

PL-2303HX provides a convenient solution for connecting an RS232-like full-duplex asynchronous serial device to any Universal Serial Bus (USB) capable host. PL-2303HX highly compatible drivers could simulate the traditional COM port on most operating systems allowing the existing applications based on COM port to easily migrate and be made USB ready.

By taking advantage of USB bulk transfer mode, large data buffers, and automatic flow control, PL-2303HX is capable of achieving higher throughput compared to traditional UART (Universal Asynchronous Receiver Transmitter) ports. When real RS232 signaling is not required, baud rate higher than 115200 bps could be used for even higher performance. The flexible baud rate generator of PL-2303HX could be programmed to generate any rate between 75 bps and 6M bps.

PL-2303HX is exclusively designed for mobile and embedded solutions in mind, providing a small footprint that could easily fit in to any connectors and handheld devices. With very small power consumption in either operating or suspend mode, PL-2303HX is perfect for bus powered operation with plenty of power left for the attached devices. Flexible signal level requirement on the RS232-like serial port side also allows PL-2303HX to connect directly to any 3.3V~1.8V range devices.

4.0 Pin Assignment Outline

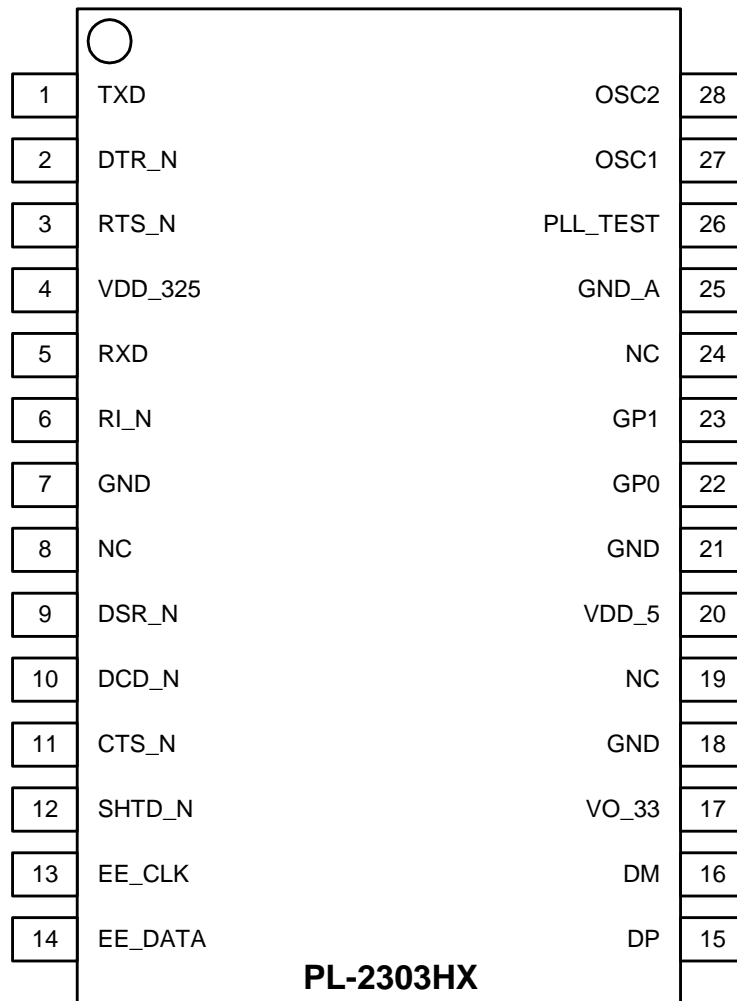

Figure 4-1 Pin Assignment Outline of PL-2303HX

5.0 Pin Assignment & Description

Table 5-1 Pin Assignment & Description

Pin #	Name	Type	Description
1	TXD	O ⁽¹⁾	Serial port (Transmitted Data)
2	DTR_N	O ⁽¹⁾	Serial port (Data Terminal Ready)
3	RTS_N	O ⁽¹⁾	Serial port (Request To Send)
4	VDD_325	P	RS232 VDD. The power pins for the serial port signals. When the serial port is 3.3V, this should be 3.3V. When the serial port is 2.5V, this should be 2.5V.
5	RXD	I ⁽²⁾	Serial port (Received Data)
6	RI_N	I/O ⁽³⁾	Serial port (Ring Indicator)
7	GND	P	Ground
8	NC		No Connect
9	DSR_N	I/O ⁽³⁾	Serial port (Data Set Ready)
10	DCD_N	I/O ⁽³⁾	Serial port (Data Carrier Detect)
11	CTS_N	I/O ⁽³⁾	Serial port (Clear To Send)
12	SHTD_N	O ⁽⁴⁾	RS232 Transceiver Shut Down Control
13	EE_CLK	I/O ⁽⁵⁾	2-Wire Serial EEPROM Clock
14	EE_DATA	I/O ⁽⁵⁾	2-Wire Serial EEPROM Data
15	DP	I/O	USB port D+ signal
16	DM	I/O	USB port D- signal
17	VO_33	P	Regulator Power Output, 3.3V
18	GND	P	Ground
19	NC		No Connect
20	VDD_5	P	USB port V _{BUS} , 5V Power.
21	GND	P	Ground
22	GP0	I/O ⁽⁷⁾	General Purpose I/O Pin 0
23	GP1	I/O ⁽⁷⁾	General Purpose I/O Pin 1
24	NC		No Connect
25	GND_A	P	Analog Ground for PLL
26	PLL_TEST	I ⁽⁶⁾	PLL test mode control
27	OSC1	I	Crystal oscillator input
28	OSC2	I/O	Crystal oscillator output

Notes:

- (1)– CMOS Out, Output Pad. Level and Driving Capability decided by VDD_325.
- (2)– SCHMITT In, 5V Tolerant, Input Pad. Level and Driving Capability decided by VDD_325.
- (3)– SCHMITT In/CMOS Out, 5V Tolerant, Bi-directional Pad. Level and Driving Capability decided by VDD_325.
- (4)– CMOS Out, 3.3V, Output Pad, 4mA Output Driving Capability.
- (5)– SCHMITT In/CMOS Out, 5V Tolerant, Bi-directional Pad with internal resistor pulling-up to 3.3V, 4mA Output Driving Capability.
- (6)– LVTTTL In, 3.3V, Input Pad.
- (7)– SCHMITT In/CMOS Out, 5V Tolerant, Bi-directional Pad, 4mA Output Driving Capability.

6.0 USB Standard Descriptors

PL-2303HX supports one configuration with one interface and four endpoints. The descriptors are basically stored in an internal Mask ROM. However, some fields could be optionally modified by properly programmed external 2-wire serial EEPROM. The contents of all descriptors are shown in the following sections.

6.1 Device Descriptor

Table 6-1 Device Descriptor

Offset	Field	Size	Value	Description
0	<i>bLength</i>	Byte	12H	Size of this descriptor (in bytes)
1	<i>bDescriptorType</i>	Byte	01H	DEVICE descriptor type
2	<i>bcdUSB</i>	Word	0110H	USB Specification Release Number 1.1
4	<i>bDeviceClass</i>	Byte	00H	
5	<i>bDeviceSubClass</i>	Byte	00H	
6	<i>bDeviceProtocol</i>	Byte	00H	
7	<i>bMaxPacketSize0</i>	Byte	40H	Maximum packet size for endpoint zero is 64
8	<i>idVender</i>	Word	067BH	Vender ID ⁽¹⁾
10	<i>idProduct</i>	Word	2303H	Product ID ⁽¹⁾
12	<i>bcdDevice</i>	Word	0300H	Device Release Number ⁽¹⁾
14	<i>iManufacturer</i>	Byte	01H	Manufacturer string descriptor index
15	<i>iProduct</i>	Byte	02H	Product name string descriptor index
16	<i>iSerialNumber</i>	Byte	00H/03H	Serial number string descriptor index ⁽²⁾
17	<i>bNumConfigurations</i>	Byte	01H	One configuration.

Notes:

- (1) – The Vender ID, Product ID, and Device Release Number could be replaced by the contents of external EEPROM.
- (2) – The serial number string descriptor index could be defined by the contents of external EEPROM. If specified, the index will be 3 instead of 0.

6.2 Configuration Descriptor

Table 6-2 Configuration Descriptor

Offset	Field	Size	Value	Description
0	<i>bLength</i>	Byte	09h	Size of this descriptor (in bytes)
1	<i>bDescriptorType</i>	Byte	02h	CONFIGURATION descriptor type
2	<i>wTotalLength</i>	Word	0027h	Total length of data returned for this configuration.
4	<i>bNumInterface</i>	Byte	01h	One interface for this device.
5	<i>bConfigurationValue</i>	Byte	01h	
6	<i>iConfiguration</i>	Byte	00h	
7	<i>bmAttributes</i>	Byte	A0h/80h	Characteristic attributes ⁽³⁾
8	<i>MaxPower</i>	Byte	32h/FAh	Maximum power consumption ⁽⁴⁾

Notes:

- (3) – The Remote Wakeup attribute (bit 5) depends on the settings of the Remote Wakeup Enable (Setting in the Device Configuration Registers, DCR, of PL-2303HX). If all remote wakeup sources are disabled, the *bmAttributes* will be 80h. Otherwise, A0h is returned to indicate that this device is Remote Wakeup capable.

- (4) – The value of maximum power consumption can be configured initially by setting DCR on the external EEPROM. If it is set to 1, the MaxPower byte will be FAh to indicate 500mA required from the USB host. Otherwise, it is 32h that indicates 100mA required.

6.3 Interface Descriptor

Table 6-3 Interface Descriptor

Offset	Field	Size	Value	Description
0	<i>BLength</i>	Byte	09h	Size of this descriptor (in bytes)
1	<i>BDescriptorType</i>	Byte	04h	INTERFACE descriptor type
2	<i>BInterfaceNumber</i>	Byte	00h	One interface only
3	<i>BAlternateSetting</i>	Byte	00h	No alternate interface
4	<i>BNumEndpoints</i>	Byte	03h	Three endpoints (excluding control endpoint)
5	<i>BInterfaceClass</i>	Byte	FFh	Vendor Specific Class
6	<i>BInterfaceSubClass</i>	Byte	00h	
7	<i>BInterfaceProtocol</i>	Byte	00h	
8	<i>IInterface</i>	Byte	00h	

6.4 Endpoint 1 Descriptor: Interrupt Input Endpoint

Table 6-4 Endpoint1 Descriptor

Offset	Field	Size	Value	Description
0	<i>bLength</i>	Byte	07h	Size of this descriptor (in bytes)
1	<i>bDescriptorType</i>	Byte	05h	ENDPOINT descriptor type
2	<i>bEndpointAddress</i>	Byte	81h	Input endpoint
3	<i>bmAttributes</i>	Byte	03h	Transfer type is INTERRUPT
4	<i>wMaxPacketSize</i>	Word	000Ah	Ten Bytes
6	<i>bInterval</i>	Byte	01h	Polling on every 1 ms interval

6.5 Endpoint 2 Descriptor: Bulk Data Output endpoint

Table 6-5 Endpoint2 Descriptor

Offset	Field	Size	Value	Description
0	<i>bLength</i>	Byte	07h	Size of this descriptor (in bytes)
1	<i>bDescriptorType</i>	Byte	05h	ENDPOINT descriptor type
2	<i>bEndpointAddress</i>	Byte	02h	Output endpoint
3	<i>bmAttributes</i>	Byte	02h	Transfer type is BULK
4	<i>wMaxPacketSize</i>	Word	0040h	64 bytes
6	<i>bInterval</i>	Byte	00h	Ignored field

6.6 Endpoint 3 Descriptor: Bulk Data Input endpoint

Table 6-6 Endpoint3 Descriptor

Offset	Field	Size	Value	Description
0	<i>bLength</i>	Byte	07h	Size of this descriptor (in bytes)
1	<i>bDescriptorType</i>	Byte	05h	ENDPOINT descriptor type
2	<i>bEndpointAddress</i>	Byte	83h	Input endpoint
3	<i>bmAttributes</i>	Byte	02h	Transfer type is BULK
4	<i>wMaxPacketSize</i>	Word	0040h	64 bytes
6	<i>bInterval</i>	Byte	00h	Ignored field

6.7 String Descriptors

PL-2303HX supports four string descriptors:

- Language ID
- Manufacturer
- Product
- Serial Number

Except for Serial Number, the other three string descriptors are stored in the internal Mask ROM, i.e. their contents are fixed. Serial Number is a special case. If the External EEPROM were not present, or not properly programmed, then Serial Number would be hidden from the system. If the External EEPROM is presented and properly programmed, then Serial Number will be read from the EEPROM.

The following tables demonstrate the current defined value for each descriptor:

6.7.1 String Descriptor 0 – Language ID

Table 6-7-1 String Descriptor – Language ID

Offset	Field	Size	Value	Description
0	<i>bLength</i>	Byte	04h	Size of this descriptor (in bytes)
1	<i>bDescriptorType</i>	Byte	03h	STRING descriptor type
2	<i>bLANGID[0]</i>	Word	0409h	English (United States)

6.7.2 String Descriptor 1 – Manufacturer

Table 6-7-2 String Descriptor – Manufacturer

Offset	Field	Size	Value	Description
0	<i>BLength</i>	Byte	32h	Size of this descriptor (in bytes)
1	<i>bDescriptorType</i>	Byte	03h	STRING descriptor type
2	<i>bSTRING</i>	—	⇒	“Prolific Technology Inc.” in UNICODE

6.7.3 String Descriptor 2 - Product

Table 6-7-3 String Descriptor – Product

Offset	Field	Size	Value	Description
0	<i>bLength</i>	Byte	2Ch	Size of this descriptor (in bytes)
1	<i>bDescriptorType</i>	Byte	03h	STRING descriptor type
2	<i>bSTRING</i>	—	⇒	“USB-Serial Controller” in UNICODE

6.7.4 String Descriptor 3 – Serial Number

Table 6-7-4 String Descriptor – Serial Number

Offset	Field	Size	Value	Description
0	<i>bLength</i>	Byte	12h	Size of this descriptor (in bytes)
1	<i>bDescriptorType</i>	Byte	03h	STRING descriptor type
2	<i>bSTRING</i>	—	⇒	“X ₇ X ₆ X ₅ X ₄ X ₃ X ₂ X ₁ X ₀ ” in UNICODE

Note:

The size of Serial Number is fixed in PL-2303HX design. It must be exactly 8 UNICODE characters (or 16 bytes). Note that in USB Specification, this serial number must be unique for each device.

7.0 USB Standard Requests

PL-2303HX supports the following USB standard requests. For non-supported requests or requests with invalid parameters, PL-2303HX will respond with STALL packet.

- Clear Feature
- Get Configuration
- Get Descriptor
- Get Status
 - Device Status
 - Interface Status
 - Endpoint 0, 1, 2, and 3 Status
- Set Address
- Set Configuration
- Set Feature

8.0 DC & Temperature Characteristics

8.1 Absolute Maximum Ratings

Table 8-1 Absolute Maximum Ratings

Items	Ratings
Power Supply Voltage	-0.3 to 5.5 V
Input Voltage of 3.3V I/O	-0.3 to VO_33 + 0.3 V
Input Voltage of 3.3V I/O with 5V Tolerance I/O	-0.3 to VDD_5 + 0.3V
Output Voltage of 3.3V I/O	-0.3 to VO_33 + 0.3 V
Storage Temperature	-40 to 150 °C

8.2 DC Characteristics

Table 8-2 Operating Voltage and Suspend Current

Parameter	Symbol	Min	Typ	Max	Unit
Operating Voltage Range	VDD_5	3.6	5	5.5	V
Regulator Output Driving Current (VDD_5= 5V)	I _{LOAD}	-	-	150	mA
Suspend Current	I _{SUS}	-	400	450	μA

8.2.1 3.3V I/O Pins

Table 8-2-1 3.3V I/O Pins

Parameter	Symbol	Min	Typ	Max	Unit
Output Driving Capability	I _{DD}	--	4	--	mA
Output Voltage of Regulator	VO_33	3.0	3.3	3.6	V
Input Voltage (CMOS)					
Low	V _{IL}	--	--	0.3* VO_33	V
High	V _{IH}	0.7* VO_33	--	--	V
Input Voltage (LVTTTL)					
Low	V _{IL}	--	--	0.8	V
High	V _{IH}	2.0	--	--	V
Schmitt Trigger Threshold Voltage					
Negative going	V _{t-}	0.9	1.2	--	V
Positive going	V _{t+}	--	2.1	2.5	V
Output Voltage, 3.3V					
Low	V _{OL}	--	--	0.4	V
High	V _{OH}	2.4	--	--	V

8.2.2 Serial I/O Pins

Table 8-2-2a VDD_325@3.3V Serial I/O Pins

Parameter	Symbol	Min	Typ	Max	Unit
Output Driving Capability	I_{DD}	--	4	--	mA
Power Supply for Serial I/O Pins	VDD_325	3.0	3.3	3.6	V
Input Voltage					
Low	V_{IL}	--	--	0.8	V
High	V_{IH}	2.0	--	--	V
Schmitt Trigger Threshold Voltage					
Negative going	V_{t-}	0.8	1.1	--	V
Positive going	V_{t+}	--	1.6	2.0	V
Output Voltage					
Low	V_{OL}	--	--	0.4	V
High	V_{OH}	2.4	--	--	V

Table 8-2-2b VDD_325@2.5V Serial I/O Pins

Parameter	Symbol	Min	Typ	Max	Unit
Output Driving Capability	I_{DD}	--	2.6	--	mA
Power Supply for Serial I/O Pins	VDD_325	2.25	2.5	2.75	V
Input Voltage					
Low	V_{IL}	--	--	0.25* VDD_325	V
High	V_{IH}	0.7* VDD_325	--	--	V
Schmitt Trigger Threshold Voltage					
Negative going	V_{t-}	0.25* VDD_325	0.84	--	V
Positive going	V_{t+}	--	1.31	0.7* VDD_325	V
Output Voltage					
Low	V_{OL}	--	--	0.4	V
High	V_{OH}	1.85	--	--	V

Table 8-2-2c VDD_325@1.8V Serial I/O Pins

Parameter	Symbol	Min	Typ	Max	Unit
Output Driving Capability	I_{DD}	--	1.4	--	mA
Power Supply for Serial I/O Pins	VDD_325	1.65	1.8	1.95	V
Input Voltage					
Low	V_{IL}	--	--	0.25* VDD_325	V
High	V_{IH}	0.7* VDD_325	--	--	V
Schmitt Trigger Threshold Voltage					
Negative going	V_{t-}	0.25* VDD_325	0.6	--	V
Positive going	V_{t+}	--	1.04	0.7* VDD_325	V
Output Voltage					
Low	V_{OL}	--	--	0.4	V
High	V_{OH}	1.25	--	--	V

8.3 Clock Characteristics

Table 8-3 Clock Characteristics

Parameter	Min	Typ	Max	Units
Frequency of Operation	11.976	12.000	12.024	MHz
Clock Period	83.1	83.3	83.5	ns
Duty Cycle	45	50	55	%

8.4 Temperature Characteristics

Table 8-4 Temperature Characteristics

Parameter	Symbol	Min	Typ	Max	Unit
Operating Temperature	--	-40 ⁽¹⁾	--	85 ⁽¹⁾	°C
Junction Operation Temperature	T _J	-40	25	125	°C

Note: (1) – Test condition: Baud rate 115200 bps loop testing (4096 bytes/loop, random/fix 0xFF data transfer) over 30 minutes.

8.5 Leakage Current and Capacitance

Table 8-5 Leakage Current and Capacitance

Parameter	Symbol	Min	Typ	Max	Unit
Input Leakage Current* ¹	I _L	-10	±1	10	μA
Tri-state Leakage Current	I _{oz}	-10	±1	10	μA
Input Capacitance	C _{IN}	--	2.8	--	pF
Output Capacitance	C _{OUT}	2.7	--	4.9	pF
Bi-directional Buffer Capacitance	C _{BID}	2.7	--	4.9	pF

Note:

*1. No pull-up or pull-down resistor.

8.6 Power-On Reset

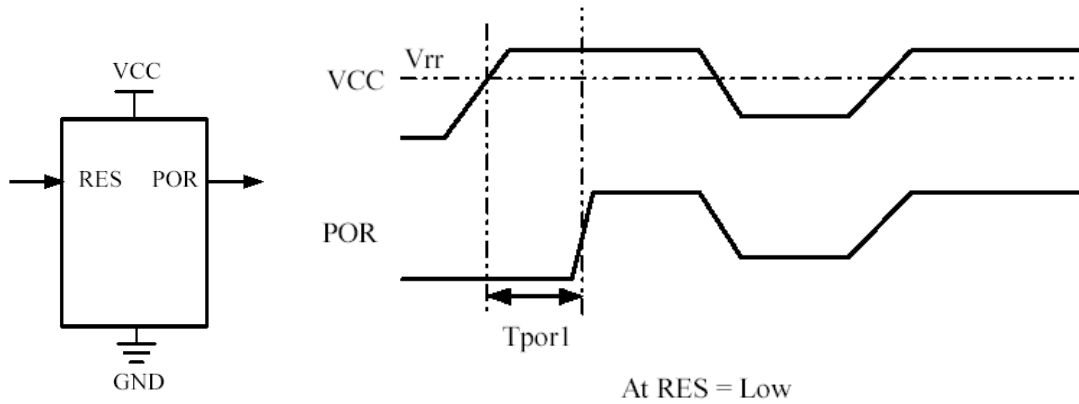

Figure 8-1 Power-On Reset Diagram

Table 8-6 Power-On Reset

Description and Condition	Symbol	Min	Typ	Max	Unit
Power supply voltage	VCC	2.8	3.3	4.0	V
VCC rise relax voltage	V _{rr}	1.8	2.3	2.8	V
Power output low duration VCC _{rise} @ V _{rr} to POR _{rise} @ 1/2*VCC (VCC slew rate = 1V/1us)	T _{por1}	2.6	3.7	4.8	μS

9.0 Outline Diagram

9.1 SSOP28 Package

Table 9-1 Package Dimension

Symbol	Millimeter			Inch		
	Min	Nom	Max	Min	Nom	Max
b	0.22		0.38	0.009		0.015
E	7.40	7.80	8.20	0.291	0.307	0.323
E1	5.00	5.30	5.60	0.197	0.209	0.220
L	0.55	0.75	0.95	0.021	0.030	0.037
R1	0.09			0.004		
D	9.9	10.2	10.5	0.390	0.402	0.413
A			2.0			0.079
e		0.65			0.0256	
L1		1.25			0.050	
A1	0.05			0.020		
A2	1.65	1.75	1.85	0.065	0.069	0.073

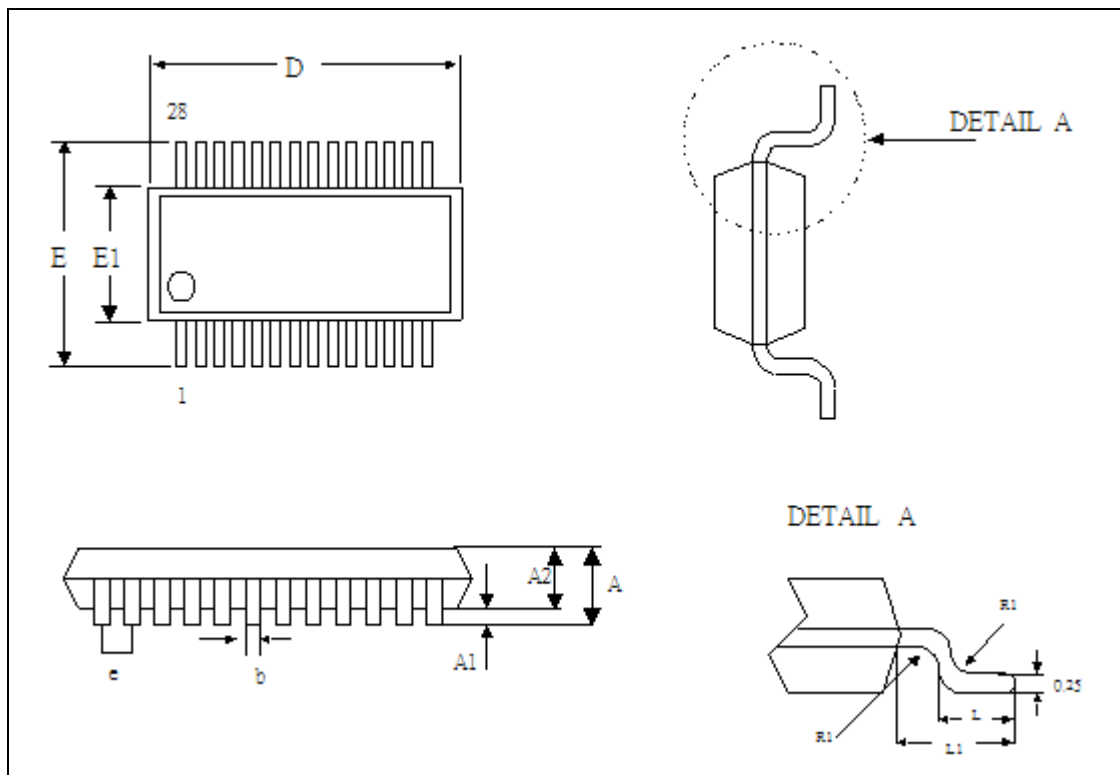

Figure 9-1 Outline Diagram of PL-2303HX SSOP28

10.0 Reel Packing Information

10.1 Carrier Tape (SSOP-28)

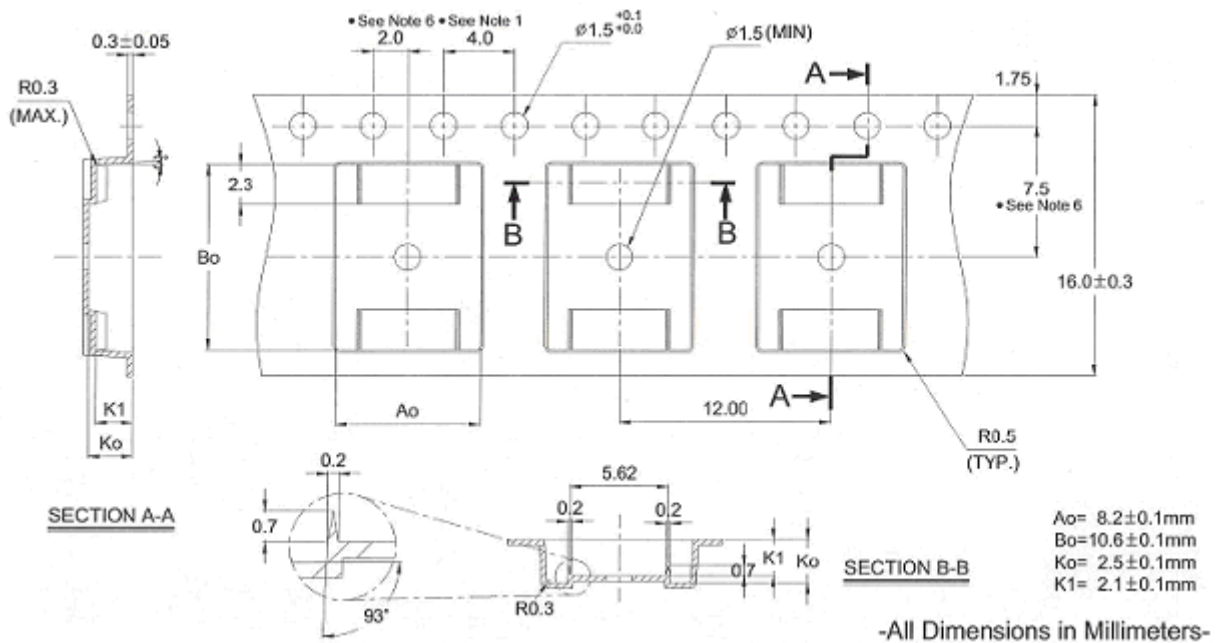

Figure 10-1a SSOP28 Carrier Tape

Notes:

- 10 sprocket hole pitch cumulative tolerance ± 0.2
- Camber not to exceed 1mm in 100mm.
- Material: Black Polystyrene.
- Ao and Bo measured on a plane 0.3mm above the bottom of the pocket.
- Ko measured from a plane on the inside bottom of the pocket to the top surface of the carrier.
- Pocket position relative to sprocket hole measured as true position of pocket, not pocket hole.
- IC quantity per one reel: 1,000 (min) ~ 2,000 (max)

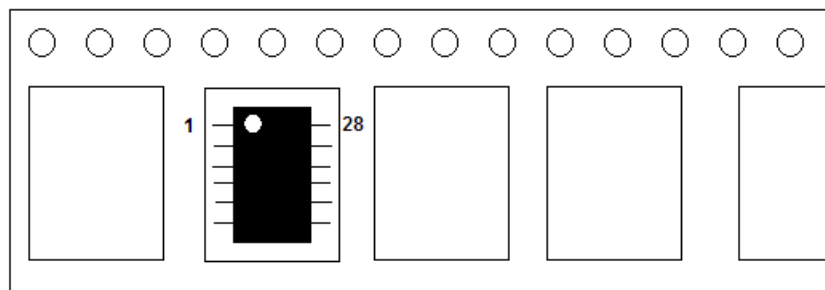

Figure 10-1b IC Reel Placements

10.2 Reel Dimension

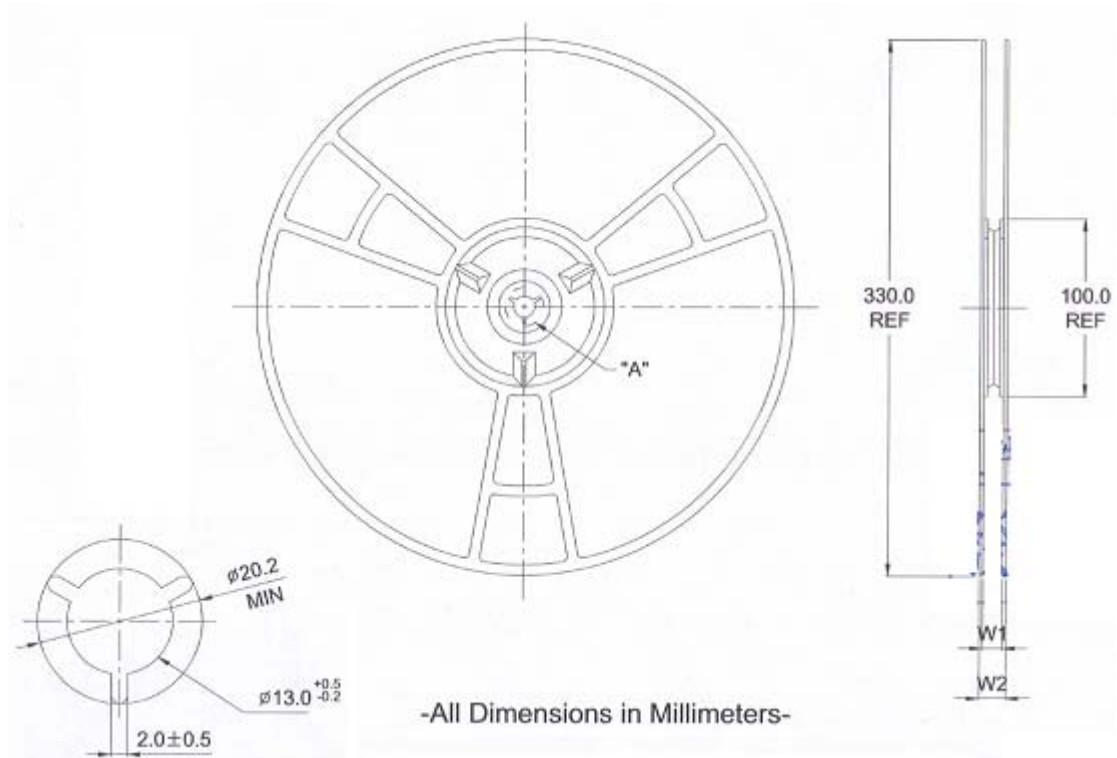

Figure 10-2 Reel Dimension

Table 10-2 Reel Part Number Information

Part Number	Normal Hub Width	W1 +0.3mm -0.2mm	W2 Max
RD33008SW-T + RD33008SW-T	16mm	16.8mm	22.2mm

11.0 Ordering Information

Table 11-1 Ordering Information

Part Number	Package Type
PL-2303HX	28-pin SSOP
PL-2303HX LF	28-pin SSOP (Lead-Free or Pb-Free)